

G503 WWII Jeep Removing Rear Brake Drum

This article shows the steps for removing the WWII Jeep Rear Brake Drum

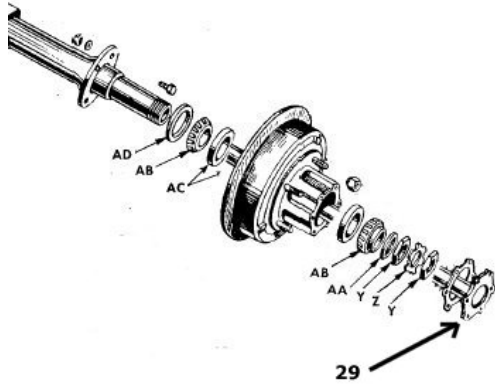

Removing the Rear brake drums is a little less involved than the front, but very similar. Here you see that there is a difference in that you will remove #29 the rear axle shaft in order to get to the wheel bearing nuts.



First, remove the 6 axle shaft bolts.



Next, slide the rear axle shaft out of the axle. While it is out, inspect the teeth at the end of the shaft looking for wear on the teeth.



Check to see if the lock washer has been bent to lock the wheel bearing nut. If so, you will need to bend the washer back so you can unscrew the wheel bearing nut.



Next, use your wheel bearing nut tool to unscrew the first of two nuts.



The wheel bearing lock washer can be removed by pulling it out straight. Sometimes you have to finesse this part out with a screwdriver and your fingers. Note: the lockwasher has a notch that is held in the axle housing, so it will not spin.



Now remove the second wheel bearing nut from the axle housing shaft with your tool.



At this point, by pulling on the rear brake drum you will see that it will start to come off. NOTE: be carefull of the wheel bearings falling out. Here you see they are ready to drop.



And your drum should be off and now you can inspect your brake pads.